

PRODUCT SPECIFICATION

Part Number	MEM2050	Rev	A	Date	11/06/09		
Product Description	Micro SD Memory Card Connector, Push-Push, SMT, Card Entry Normal, 1.90mm Profile.			Page	1		
Doc Number	MEM2050	Prepared	BW	Checked	PN	Approved	DR

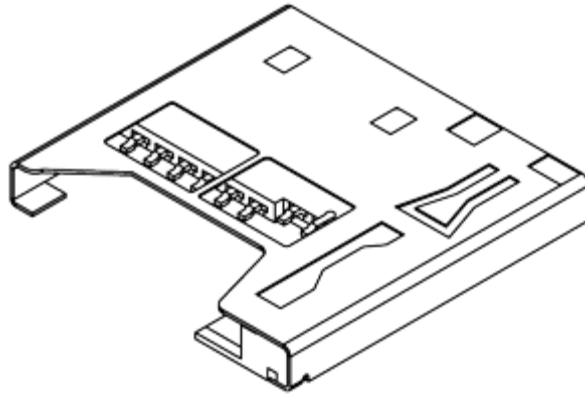

GCT

PRODUCT SPECIFICATION

Part Number	MEM2050	Rev	A	Date	11/06/09
Product Description	Micro SD Memory Card Connector, Push-Push, SMT, Card Entry Normal, 1.90mm Profile.			Page	2
Doc Number	MEM2050	Prepared	BW	Checked	PN
				Approved	DR

1.0 SCOPE.

This specification covers performance, test and quality requirements for the Micro SD Memory Card Connector Normally open Mem2050 (Push-Push Type, SMT, 1.90mm Profile.).

2.0 PRODUCT NAME AND PART NUMBER.

Memory Card Connector, Push-Push Type: Mem2050.

3.0 PRODUCT SHAPE, DIMENSIONS AND MATERIAL.

Please refer to drawings.

4.0 RATINGS.

- 4.1 Current rating 0.5A DC Max
- 4.2 Voltage rating 100 Volts AC(RMS)
- 4.3 Operating Temperature Range -25°C TO +85°C

5.0 TEST AND MEASUREMENT CONDITIONS.

Product is designed to meet electrical, mechanical and environmental performance requirements specified in Paragraph 6.0. All tests are performed in ambient conditions unless otherwise specified.

6.0 PERFORMANCE.

Item	Test Condition	Requirement
Examination of Product	Visual, dimensional and functional inspection as per quality plan.	Product shall meet requirements of product drawing and specification.

PRODUCT SPECIFICATION

Part Number	MEM2050	Rev	A	Date	11/06/09
Product Description	Micro SD Memory Card Connector, Push-Push, SMT, Card Entry Normal, 1.90mm Profile.			Page	3
Doc Number	MEM2050	Prepared	BW	Checked	PN
				Approved	DR

6.1 Electrical Performance.

Item	Test Condition	Requirement
Contact Resistance	Measure and record contact resistance of mated connector using test current of 10mA max and 20 mV open circuit voltage in accordance with EIA-364-6B	Less than 100 mΩ at end of test
Insulation Resistance	Apply 500Volts DC between adjacent contacts of mated connectors for one minute in accordance with EIA-364-21C	Greater than 500 MΩ
Dielectric Strength	Mate connectors and apply 500 V AC for 1 minute between adjacent terminal ground, in accordance with EIA-364-20B.	No creeping discharge or flash over. Current leakage less than 1.0mA

6.2 Mechanical Performance.

Item	Test Condition	Requirement
Contact Force	Using a push-pull gauge perform insertion and removal of connector at a speed of 25mm/min.	13.8 N max
Durability	The connector should be mated and unmated for 5000 cycles with 0.6mm travel.	No evidence of physical damage. Contact Resistance $\leq 100m\Omega$ at end of test .
Vibration	Subject mated connectors to 10 to 55 to 10 Hz frequency span over 1 minute at a 1.5mm amplitude. Test to be conducted on 3 mutually perpendicular planes with 100mA applied and in accordance with EIA -364-28D.	No electrical discontinuity greater than 1 μ sec. shall occur. No damage to product.
Mechanical Shock	Apply DC and 1mA to all contacts and subject the part to a 294 m/s ² half sine wave acceleration for 11 ms. Three shocks to be applied in each of the X, Y and Z planes and in both directions. A total of 18 shocks and in accordance with EIA-364-27B.	No electrical discontinuity greater than 1 μ sec. shall occur. No damage to product.

GCT

PRODUCT SPECIFICATION

Part Number	MEM2050	Rev	A	Date	11/06/09
Product Description	Micro SD Memory Card Connector, Push-Push, SMT, Card Entry Normal, 1.90mm Profile.			Page	4
Doc Number	MEM2050	Prepared	BW	Checked	PN
				Approved	DR

6.3 Environmental Performance and Others.

Item	Test Condition	Requirement
Thermal Shock	Mate Connector and perform the following thermal cycle :- -55+/-3°C for 30 minutes. . +85+/-2°C for 30 minutes. Repeat for 5 cycles in accordance with EIA-364-32C.	No evidence of physical damage, discharge, flashes or corrosion in contact areas. Contact Resistance Less than 100mΩ at end of test. Insulation Resistance greater than 1000Ω at end of test.
Humidity Test	Mate connector and expose to temperature of 40±2°C with 95% RH for 96 hours then place in ambient temperature for 1 to 2 hrs. In accordance with EIA-364-31 method iii.	
Salt Water Spray	Subject mated connectors to 35±2°C and 5±1% salt condition for 48hours. Test in accordance with EIA-364-26B	
Temperature Life (High)	Subject product to 85±2°C for 96 hours continuously in accordance with EIA-364-17B	
Solderability	Dip solders tails into molten solder, held at a temperature of 245±5°C for 5±0.5 seconds, in accordance with EIA-364-52.	95% of immersed area must show no voids of pin holes.
Resistance to Reflow Soldering Heat.	Mount connector, place in reflow oven and expose to the temperature profile shown in fig 1.0	No evidence of physical damage or abnormalities adversely affecting performance.

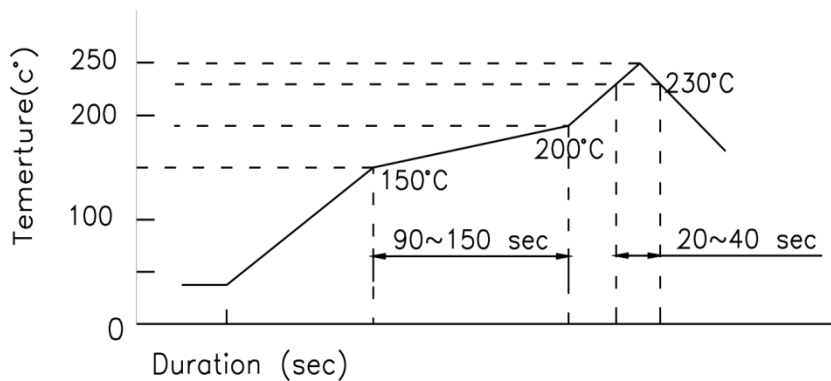

Fig.1. Recommended Reflow Temp. Profile

PRODUCT SPECIFICATION

Part Number	MEM2050	Rev	A	Date	11/06/09
Product Description	Micro SD Memory Card Connector, Push-Push, SMT, Card Entry Normal, 1.90mm Profile.			Page	5
Doc Number	MEM2050	Prepared	BW	Checked	PN
		Approved	DR		

7.0 PRODUCT QUALIFICATION AND TEST SEQUENCE

Test Item	Group						
	A	B	C	D	E	F	G
Examination of Product	1,7	1,10	1,10	1,5	1,5	1,3	1,3
Contact Resistance	3,6	2,7	2,7	2,4	2,4		
Insulation Resistance		3,8	3,8				
Dielectric Withstanding Voltage		4,9	4,9				
Mechanical shock		6					
Card insertion /Withdrawal force.	2,5						
Durability	4						
Vibration		5					
Humidity			6				
Salt Water Spray				3			
Temperature Life					3		
Thermal Shock			5				
Solderability						2	
Resistance to Reflow Soldering heat							2
Sample QTY.	5	5	5	5	5	5	5

GCT

Contact details

Asia Pacific

Global Connector Technology HK Limited
Unit 1204, 12/F, Fortress Tower,
250 King's Road
North Point,
Hong Kong, PRC.

Tel: +852 2578 9030
Fax: +852 2578 9000
Email: sales@gct-apac.com

Americas

Global Connector Technology, Inc.
3 Industrial Park Road,
Medway, MA 02053
USA

Tel: +1 508-570-2438
E-mail: sales@gct-america.com

Europe

Global Connector Technology Europe Limited
7 Sutherland Court
Brownfields
Welwyn Garden City, Hertfordshire
AL7 1BJ
United Kingdom.

Tel: +44 (0)1707 321122
Fax: +44 (0)1707 321121
E-mail: sales@gct-europe.com

Global Connector Technology Limited makes no representation that the use of its products in the circuits described herein, or the use of other technical information contained herein, will not infringe upon existing or future patent rights. The descriptions contained herein do not imply the granting of licenses to make, use, or sell equipment constructed in accordance therewith. Specifications are subject to change without notice. Errors and Omissions Excepted.

GCT

www.globalconnectortechnology.com