

PRODUCT SPECIFICATION

Part Number	SIM2060	Rev	A	Date	11/06/09		
Product Description	SIM Card Connector, Receiver Type, 6Pin, SMT, 1.8, 2.0 & 2.2mm Profile Options.				Page	1	
Doc Number	SIM2060	Prepared	BW	Checked	PN	Approved	DR

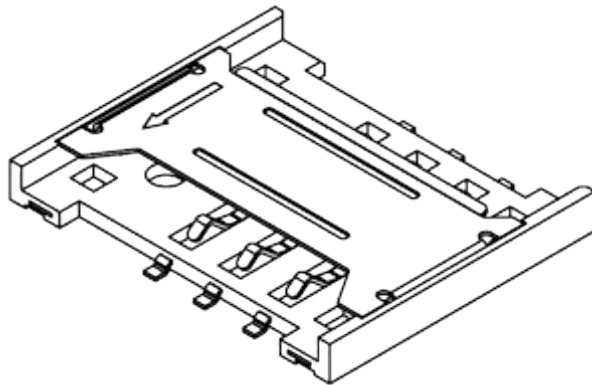

GCT

PRODUCT SPECIFICATION

Part Number	SIM2060	Rev	A	Date	11/06/09
Product Description	SIM Card Connector, Receiver Type, 6Pin, SMT, 1.8, 2.0 & 2.2mm Profile Options.			Page	2
Doc Number	SIM2060	Prepared	BW	Checked	PN
		Approved	DR		

1.0 SCOPE.

This specification covers performance, tests and quality requirements for the SIM Card Connector SIM2060 (Receiver Type, 6-Pin, SMT, 1.8, 2.0 & 2.2mm Profiles).

2.0 PRODUCT NAME AND PART NUMBER.

SIM Card Connector, 6 Pin, Receiver Type: SIM2060.

3.0 PRODUCT SHAPE, DIMENSIONS AND MATERIAL.

Please refer to drawings.

4.0 RATINGS.

- Current rating 1.0 Amp max
- Voltage rating 250 Volts AC (rms.) Max.
- Operating Temperature Range -55°C to +105°C
- Storage Temperature -40°C to +105°C

5.0 TEST AND MEASUREMENT CONDITIONS.

Product is designed to meet electrical, mechanical and environmental performance requirements specified in Paragraph 6.0. All tests are performed at ambient environmental conditions unless otherwise specified.

6.0 PERFORMANCE.

Item	Test Condition	Requirement
Examination of Product	Visual, dimensional and functional inspection as per quality plan.	Product shall meet requirements of product drawing and specification.

PRODUCT SPECIFICATION

Part Number	SIM2060	Rev	A	Date	11/06/09
Product Description	SIM Card Connector, Receiver Type, 6Pin, SMT, 1.8, 2.0 & 2.2mm Profile Options.			Page	3
Doc Number	SIM2060	Prepared	BW	Checked	PN
		Approved	DR		

6.1 Electrical Performance.

Item	Test Condition	Requirement
Contact Resistance	Measure and record contact resistance of mated connector using test current of 100mA max and 20 mV open circuit voltage in accordance with EIA-364-23A.	50 mΩ Max Initial 100 mΩ Max after test.
Insulation Resistance	Apply 250Volts DC between adjacent contacts of mated connectors for one minute in accordance with EIA-364-21A.	100 MΩ minimum
Dielectric Strength	Mate connectors and apply 100 V AC for 1 minute between adjacent terminal or ground, in accordance with EIA-364-20A.	No creeping discharge or flash over. Current leakage: 0.5 A max.

6.2 Mechanical Performance.

Item	Test Condition	Requirement
Contact Force	Apply axial pull out force on the connector assembled in the housing at a speed: 25±3 mm/minute.	50gf /pin Min.
Durability	The connector should be mated and unmated for 5000 cycles at a rate of 20 cycles/ minute in accordance with EIA-RS-364-09A.	No evidence of physical damage. Contact Resistance ≤ 100mΩ at end of test .
Vibration	Subject mated connectors to 10 to 55 to 10 Hz frequency span over 1 minute at a 1.52mm amplitude for a total of 15 minutes. Test to be conducted on 3 mutually perpendicular planes. 100mA Max. Applied. In accordance with EIA-364-28.	No evidence of physical damage Contact Resistance ≤ 100mΩ Current discontinuity ≤ 0.1 μs at end of test
Mechanical Shock	Apply 5V DC and 100mA to all contacts and subject the part to a 490 m/s ² half sine wave acceleration for 11 ms. Three shocks to be applied in each of the X, Y and Z planes and in both directions. A total of 18 shocks and in accordance with EIA-364-27.	No evidence of physical damage Contact Resistance ≤ 100mΩ Current discontinuity ≤ 10 μs at end of test .

PRODUCT SPECIFICATION

Part Number	SIM2060	Rev	A	Date	11/06/09
Product Description	SIM Card Connector, Receiver Type, 6Pin, SMT, 1.8, 2.0 & 2.2mm Profile Options.			Page	4
Doc Number	SIM2060	Prepared	BW	Checked	PN
		Approved	DR		

6.3 Environmental Performance and Others.

Item	Test Condition	Requirement
Thermal Shock	Mate Connector and perform the following thermal cycle :- -55+/-3°C for 30 minutes. +5°C to +35°C for 5 minutes. +85+/-2°C for 30 minutes. +5°C to +35°C for 5 minutes. Repeat for 5 cycles in accordance with EIA-364-32C.	No evidence of physical damage, discharge, flashes or corrosion in contact areas. Contact Resistance $\leq 100 \text{ m}\Omega$ Insulation Resistance $\geq 100 \text{ M}\Omega$
Humidity Test	Mate connector and expose to temperature of 40±2°C with 95% RH for 96 hours then place in ambient temperature for 1 to 2 hrs. In accordance with EIA-RS-364-31A.	
Salt Water Spray	Subject mated connectors to 35±2°C and 5±1% salt condition for 48hours. Test in accordance with EIA-RS-364-26A.	
Temperature Life (High)	Subject mated connectors to 85°C ±2°C for 96 hours in accordance with MTL-STD-202F, Method 108A.	
Solderability	Dip solders tails into molten solder, held at a temperature of 235±5°C for 5±0.5 second, in accordance with EA-364-52.	
Resistance to Reflow Soldering Heat.	Mount connector, place in reflow oven and expose to the temperature profile shown in fig 1.0.	No evidence of physical damage or abnormalities adversely affecting performance.

PRODUCT SPECIFICATION

Part Number	SIM2060	Rev	A	Date	11/06/09		
Product Description	SIM Card Connector, Receiver Type, 6Pin, SMT, 1.8, 2.0 & 2.2mm Profile Options.				Page	5	
Doc Number	SIM2060	Prepared	BW	Checked	PN	Approved	DR

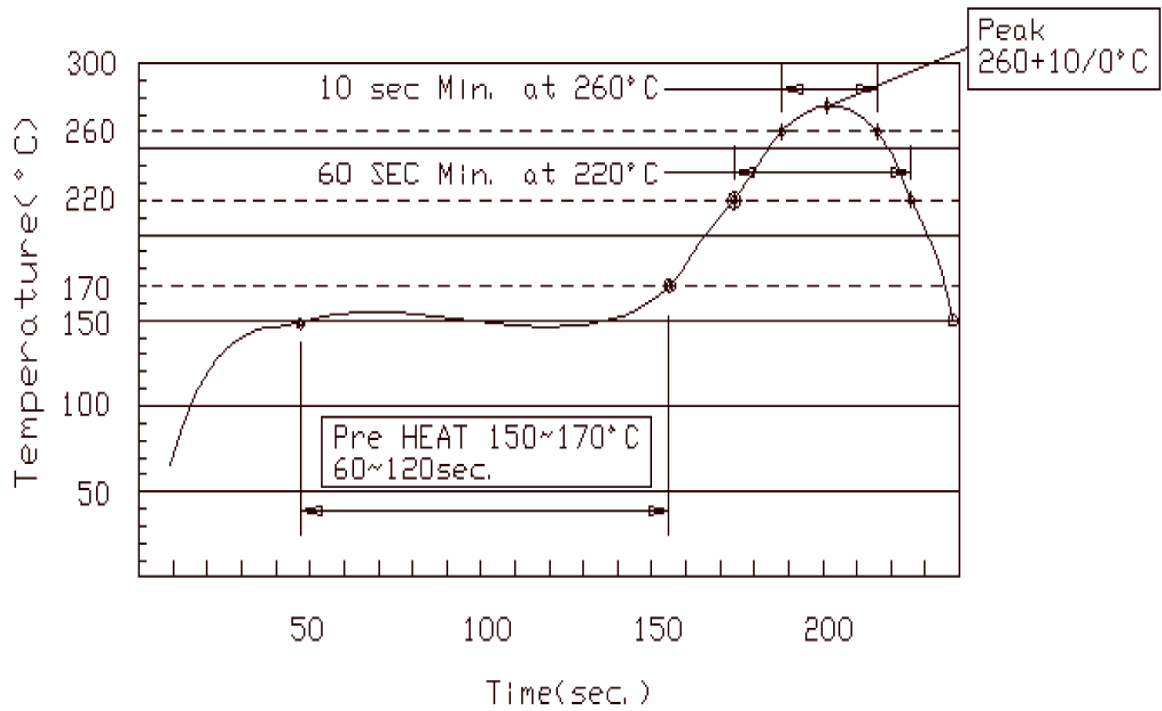

Fig. 1. Recommended Reflow Temp. Profile

PRODUCT SPECIFICATION

Part Number	SIM2060	Rev	A	Date	11/06/09		
Product Description	SIM Card Connector, Receiver Type, 6Pin, SMT, 1.8, 2.0 & 2.2mm Profile Options.				Page	6	
Doc Number	SIM2060	Prepared	BW	Checked	PN	Approved	DR

7.0 PRODUCT QUALIFICATION AND TEST SEQUENCE

Test Item	Group							
	A	B	C	D	E	F	G	H
Examination of Product	1,5	1,5	1,5	1,8	1,7	1,6	1,4	1,3
Contact Resistance	2,4	2,4	2,4	2,6	2,6	2,5		
Insulation Resistance				3,5				
Dielectric Withstanding Voltage				7				
Contact Force					3,5			
Durability					4			
Vibration						3		
Mechanical Shock						4		
Thermal Shock	3							
Humidity				4				
Salt Water Spray		3						
Temperature Life			3					
Solderability								2
Resistance to Reflow Soldering Heat.							2	
Sample QTY.	5	5	5	5	5	5	5	5

Notes:

Numbers indicate sequence in which tests are performed.

Precondition samples with 10 cycle's durability.

SAMPLE SELECTION

Samples shall be prepared in accordance with applicable manufactures' instructions and shall be randomly selected from current production. Test groups A,B,C,D,E,F &G shall consist of a minimum of five connectors. A minimum of 30 contacts shall be selected and identified.

Unless otherwise specified, these contacts shall be used for all measurements.

Contact details

Asia Pacific

Global Connector Technology HK Limited
Unit 1204, 12/F, Fortress Tower,
250 King's Road
North Point,
Hong Kong, PRC.

Tel: +852 2578 9030
Fax: +852 2578 9000
Email: sales@gct-apac.com

Americas

Global Connector Technology, Inc.
3 Industrial Park Road,
Medway, MA 02053
USA

Tel: +1 508-570-2438
E-mail: sales@gct-americas.com

Europe

Global Connector Technology Europe Limited
7 Sutherland Court
Brownfields
Welwyn Garden City, Hertfordshire
AL7 1BJ
United Kingdom.

Tel: +44 (0)1707 321122
Fax: +44 (0)1707 321121
E-mail: sales@gct-europe.com

Global Connector Technology Limited makes no representation that the use of its products in the circuits described herein, or the use of other technical information contained herein, will not infringe upon existing or future patent rights. The descriptions contained herein do not imply the granting of licenses to make, use, or sell equipment constructed in accordance therewith. Specifications are subject to change without notice. Errors and Omissions Excepted.

GCT

www.globalconnectortechnology.com