

# PRODUCT SPECIFICATION

<b>Part Number</b>	USB2055	<b>Rev</b>	A	<b>Date</b>	11/06/09		
<b>Product Description</b>	Mini USB Receptacle, Type B, 5 Pin, SMT, Horizontal, Offset 1.5mm,with Post			<b>Page</b>	1		
<b>Doc Number</b>	USB2055	<b>Prepared</b>	<b>BW</b>	<b>Checked</b>	<b>PN</b>	<b>Approved</b>	<b>DR</b>

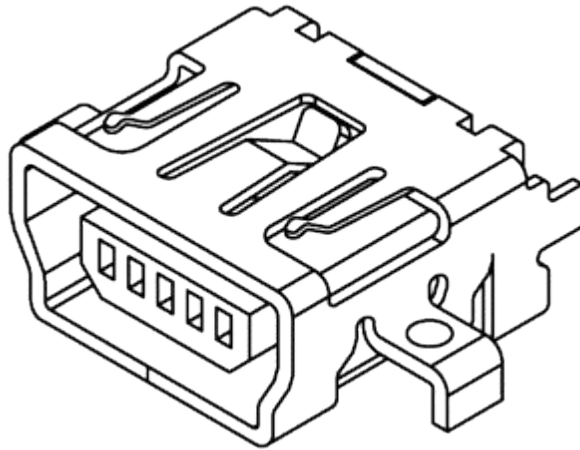

# GCT

# PRODUCT SPECIFICATION

<b>Part Number</b>	USB2055	<b>Rev</b>	A	<b>Date</b>	11/06/09		
<b>Product Description</b>	Mini USB Receptacle, Type B, 5 Pin, SMT, Horizontal, Offset 1.5mm,with Post			<b>Page</b>	2		
<b>Doc Number</b>	USB2055	<b>Prepared</b>	<b>BW</b>	<b>Checked</b>	<b>PN</b>	<b>Approved</b>	<b>DR</b>

## 1.0 SCOPE.

This specification covers performance, tests and quality requirements for the Mini USB Receptacle USB 2055 (Type B, 5-Pin, SMT, Horizontal).

## 2.0 PRODUCT NAME AND PART NUMBER.

Mini USB Receptacle, 5 Pin, Type B: USB 2055.

## 3.0 PRODUCT SHAPE, DIMENSIONS AND MATERIAL.

Please refer to drawings.

## 4.0 RATINGS.

- 4.1 Current rating ..... 1.0 A Max.
- 4.2 Voltage rating ..... 30 Volts DC
- 4.3 Operating Temperature Range ..... 0°C TO +50°C

## 5.0 TEST AND MEASUREMENT CONDITIONS.

Product is designed to meet electrical, mechanical and environmental performance requirements specified in Paragraph 6.0. All tests are performed in ambient conditions unless otherwise specified.

## 6.0 PERFORMANCE.

Item	Test Condition	Requirement
Examination of Product	Visual, dimensional and functional inspection as per quality plan.	Product shall meet requirements of product drawing and specification.

# PRODUCT SPECIFICATION

<b>Part Number</b>	USB2055	<b>Rev</b>	A	<b>Date</b>	11/06/09		
<b>Product Description</b>	Mini USB Receptacle, Type B, 5 Pin, SMT, Horizontal, Offset 1.5mm,with Post			<b>Page</b>	3		
<b>Doc Number</b>	USB2055	<b>Prepared</b>	<b>BW</b>	<b>Checked</b>	<b>PN</b>	<b>Approved</b>	<b>DR</b>

## 6.1 Electrical Performance.

Item	Test Condition	Requirement
Contact Resistance	Measure and record contact resistance of mated connector using test current of 10mA max and 20 mV open circuit voltage in accordance with EIA-364-23B.	Less than 50 mΩ at end of test
Insulation Resistance	Apply 100Volts DC between adjacent contacts of mated connectors for one minute in accordance with EIA-364-21C.	Greater than 100 MΩ
Dielectric Strength	Mate connectors and apply 100 V AC for 1 minute between adjacent terminal ground in accordance with EIA-364-20B.	No creeping discharge or flash over.

## 6.2 Mechanical Performance.

Item	Test Condition	Requirement
Contact force	Apply axial pull out force on the connector assembled in the housing at a speed: 25 ± 3 mm/minute. In accordance with EIA364-29B.	35N Min
Durability	The connector should be mated and unmated for 5000 cycles at a rate of 200 cycles per hour.	No evidence of physical damage.  Contact Resistance ≤ 50mΩ at end of test .
Vibration	Subject mated parts to 5.35G at a 50 to 2000Hz frequency span for 15 minutes in each of 3 mutually perpendicular planes in accordance with EIA-364-28D.	No electrical discontinuity greater than 1 μ sec. shall occur. No damage to product.
Mechanical Shock	Subject mated parts to 30G half-sine shock pulses for 11 ms. Apply three shocks in each direction applied along three mutually perpendicular planes in accordance with EIA-364-27B.	No electrical discontinuity greater than 1 μ sec. shall occur. No damage to product. Contact Resistance ≤ 100mΩ at end of test .

# PRODUCT SPECIFICATION

<b>Part Number</b>	USB2055	<b>Rev</b>	A	<b>Date</b>	11/06/09		
<b>Product Description</b>	Mini USB Receptacle, Type B, 5 Pin, SMT, Horizontal, Offset 1.5mm,with Post				<b>Page</b>	4	
<b>Doc Number</b>	USB2055	<b>Prepared</b>	<b>BW</b>	<b>Checked</b>	<b>PN</b>	<b>Approved</b>	<b>DR</b>

## 6.3 Environmental Performance and Others.

Item	Test Condition	Requirement
Thermal Shock	Mate Connector and perform the following thermal cycle :- -55+/-3°C to +85+/-2°C.  Repeat for 10 cycles in accordance with EIA-364-32C.	No evidence of physical damage, discharge, flashes or corrosion in contact areas.  Contact Resistance Less than 50mΩ at end of test.  Insulation Resistance greater than 100MΩ at end of test.
Humidity Test	Mate connector and expose to temperature of 25°C and 90 to 98% RH for 96 hours in accordance with EIA-RS-364-31A.	
Salt Water Spray	Subject mated connectors to 35±2°C and 5±1% salt condition for 48hours. Test in accordance with EIA-364-26B.	
Temperature Life (High)	Subject mated connectors to 85 ± 2°C for 250 hours continuously in accordance with EIA-364-17B	
Temperature Life (Low)	Subject product to -55 ± 2°C for 96 hours continuously.	
Solderability	Dip solders tails into molten solder, held at a temperature of 260 +0/-5°C, for 4.5±0.5 seconds in accordance with EIA-364-52.	
Resistance to Reflow Soldering Heat.	Mount connector, place in reflow oven and expose to the temperature profile shown in fig 1.0.	No evidence of physical damage or abnormalities adversely affecting performance.

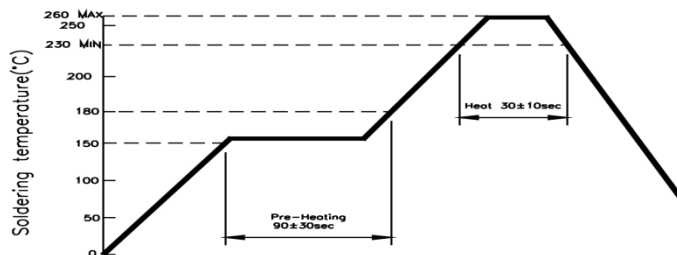

**Fig.1. Recommended Reflow Temp. Profile**

# PRODUCT SPECIFICATION

<b>Part Number</b>	USB2055	<b>Rev</b>	A	<b>Date</b>	11/06/09		
<b>Product Description</b>	Mini USB Receptacle, Type B, 5 Pin, SMT, Horizontal, Offset 1.5mm,with Post				<b>Page</b>	5	
<b>Doc Number</b>	USB2055	<b>Prepared</b>	<b>BW</b>	<b>Checked</b>	<b>PN</b>	<b>Approved</b>	<b>DR</b>

## 7.0 PRODUCT QUALIFICATION AND TEST SEQUENCE

Test Item	Test Group					
	A	B	C	D	E	F
Examination of Product	1,9	1,7	1,8	1,7	1,4	1,3
Contact Resistance	3,7	2,4,6		2,4,6		
Insulation Resistance			2,6			
Dielectric Withstanding Voltage			3,7			
Contact force					3	
Durability	5					
Mechanical Shock		5				
Vibration		3				
Humidity			4			
Thermal Shock			5			
High Temperature Life				3		
Low Temperature Life				5		
Solderability					2	
Resistance to Reflow Soldering Heat						2

## Contact details

### Asia Pacific

Global Connector Technology HK Limited  
Unit 1204, 12/F, Fortress Tower,  
250 King's Road  
North Point,  
Hong Kong, PRC.

Tel: +852 2578 9030  
Fax: +852 2578 9000  
Email: [sales@gct-apac.com](mailto:sales@gct-apac.com)

### Americas

Global Connector Technology, Inc.  
3 Industrial Park Road,  
Medway, MA 02053  
USA

Tel: +1 508-570-2438  
E-mail: [sales@gct-americas.com](mailto:sales@gct-americas.com)

### Europe

Global Connector Technology Europe Limited  
7 Sutherland Court  
Brownfields  
Welwyn Garden City, Hertfordshire  
AL7 1BJ  
United Kingdom.

Tel: +44 (0)1707 321122  
Fax: +44 (0)1707 321121  
E-mail: [sales@gct-europe.com](mailto:sales@gct-europe.com)

Global Connector Technology Limited makes no representation that the use of its products in the circuits described herein, or the use of other technical information contained herein, will not infringe upon existing or future patent rights. The descriptions contained herein do not imply the granting of licenses to make, use, or sell equipment constructed in accordance therewith. Specifications are subject to change without notice. Errors and Omissions Excepted.

# GCT

[www.globalconnectortechnology.com](http://www.globalconnectortechnology.com)