

Global Connector Technology Ltd. - USB2060: Mini USB Receptacle, Type B, 5 Pin, SMT, Horizontal

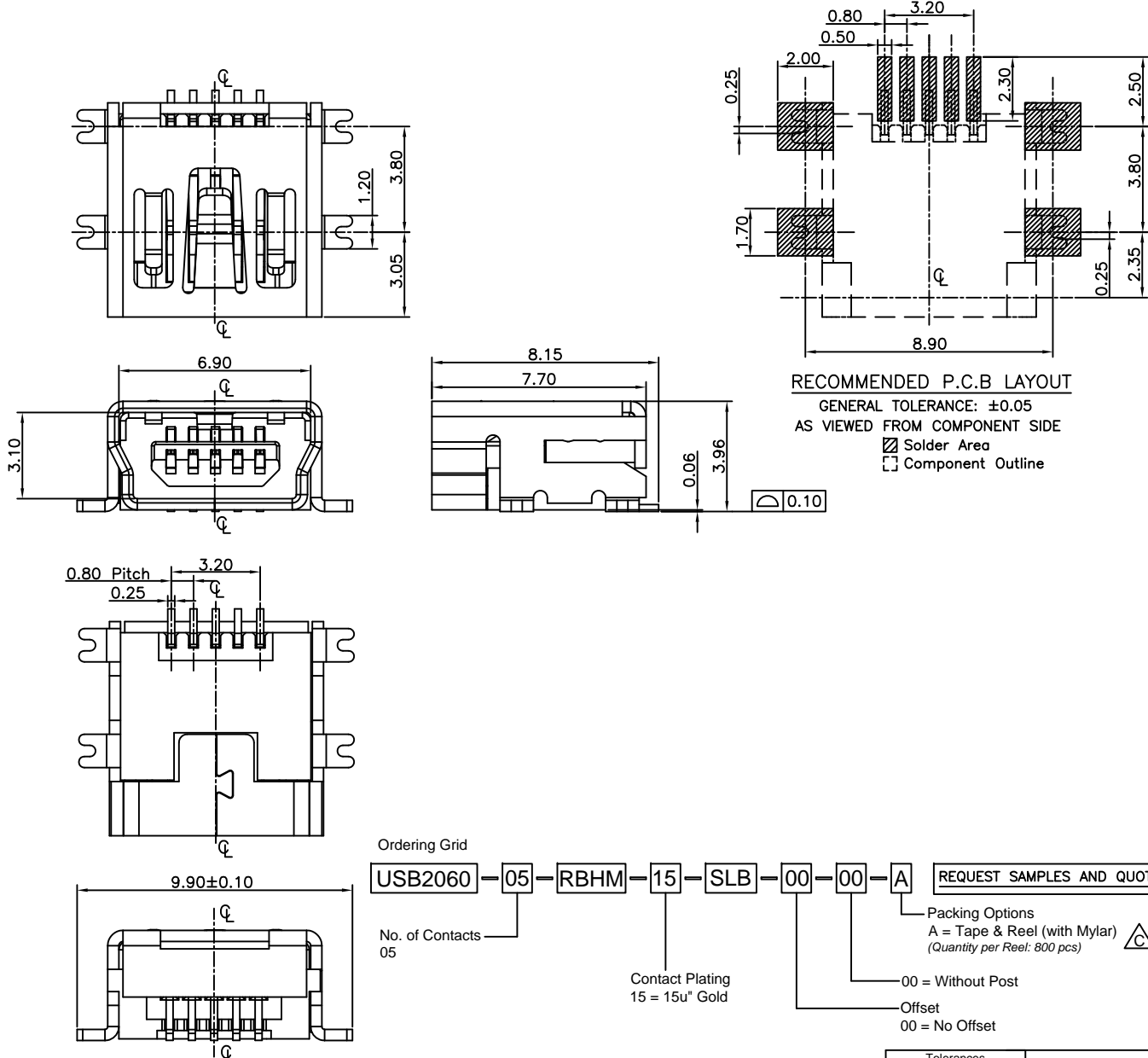

RECOMMENDED P.C.B LAYOUT
 GENERAL TOLERANCE: ±0.05
 AS VIEWED FROM COMPONENT SIDE
 ▨ Solder Area
 - - - Component Outline

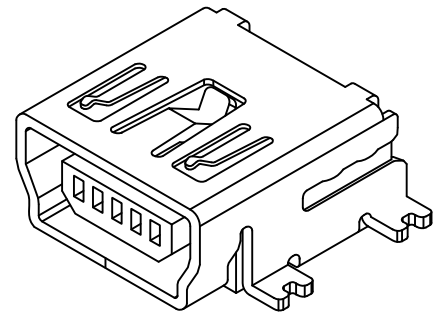

Specifications 规格:

Materials 物料规格:
 Plastic Housing 塑胶外壳: High Temp. Thermoplastic with 30% Glass Fiber, UL94V-0, Black 高温塑胶(含30%玻璃纤维), 黑色
 Contact Terminal 接触端子: Phosphor Bronze, T=0.25mm 磷青铜, T=0.25mm
 Metallic Shell 金属外壳: Stainless Steel, T=0.4±0.01mm 不锈钢

Plating 电镀规格:

Contact Terminal plating 接触端子部分电镀:
 Underplating 底层电镀: Nickel all over 全部镀镍
 Contact Area 接触部分: 15µ" Gold 镀金15µ"
 Solder Tails 焊接末端: Tin 镀锡
 Metallic Shell plating 金属外壳电镀: Copper Alloy 外壳物料: 铜合金
 Underplating 底层电镀: Nickel all over 全部镀镍
 Solder Tails 焊接末端: Matte Tin 镀雾锡

Electrical 电气规格:

Voltage Rating 电压额定值: 30VDC
 Current Rating 电流额定值: 1A
 Operating Temperature 工作温度: 0°C to +50°C
 Contact Resistance 接触电阻值: 50mΩ Max.
 Insulation Resistance 绝缘电阻值: 100MΩ Min (Apply 施加100VDC)
 Dielectric Withstanding Voltage 耐电压: No Discharge or Flash (Apply 100VAC for 1 min. 施加100VAC共一分钟)

Mechanical 机械性规格:

Mating Force 插入力: 35N (3.57Kgf) Max.
 Unmating Force 拨出力: 7N (0.71Kgf) Min.
 Contact Retention Force 接触保持力: 4N Min.
 Durability 耐久性: 5,000 Cycles 5000次插拔

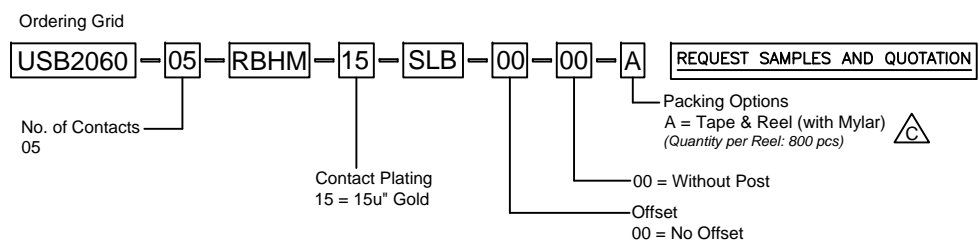

By	LYH	ASE	SA
DETAIL	DRAWING RELEASE	ECN080402A	PACK QTY UPDATE
REV DATE	A 11/07/07	B 02/04/08	C 28/06/10



Tolerances (Except as noted)	Part Number:-	Date:-
Dimensions in mm	USB2060	11 JUL 07
X.X ± 0.35 X.X° ± 1° X.XX ± 0.25 X.X° ± 0.5° X.XXX ± 0.150 X.XX° ± 0.25°	Description:-	
	MINI USB RECEPTACLE, TYPE B, 5 PIN, SMT, HORIZONTAL	
Third Angle Projection	THIS DRAWING IS CONFIDENTIAL AND MUST NOT BE COPIED OR DISCLOSED WITHOUT WRITTEN CONSENT	

GCT

www.globalconnectortechology.com

Scale	Revision	Material	Drawn by	Sheet No.
NTS	C	See Note	LYH	E & OE 1/2

Global Connector Technology Ltd. - USB2060: Mini USB Receptacle, Type B, 5 Pin, SMT, Horizontal

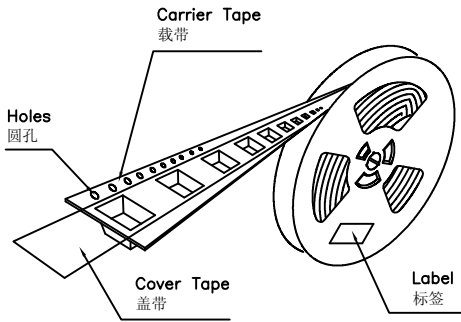
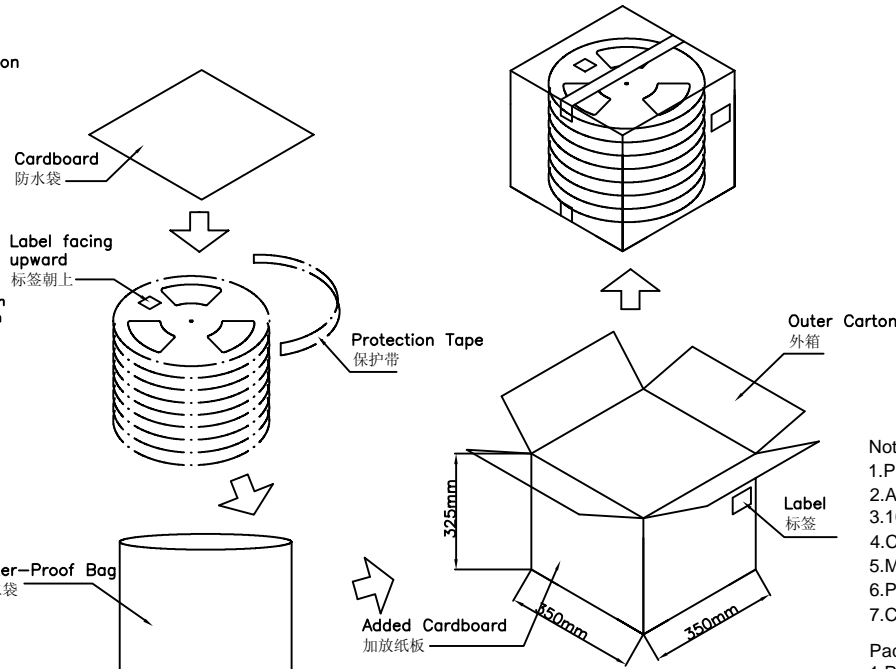
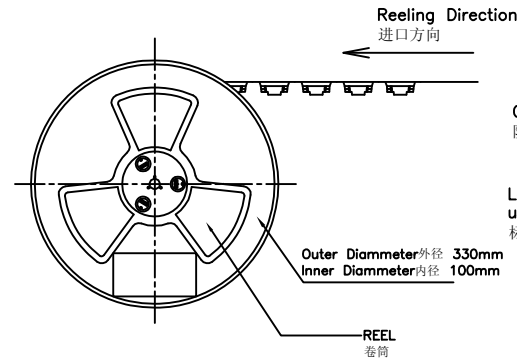
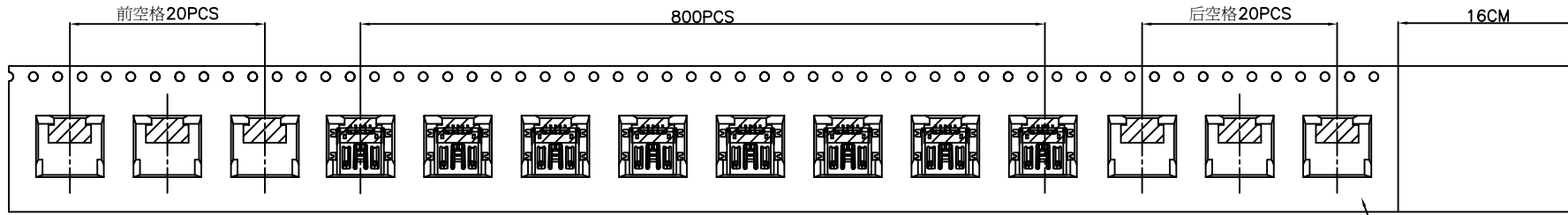

Notes 注意:

1. Part Conforms to EIA-481-C Standards 产品符合EIA-481-C标准
2. All dimensions in millimeters [inches] 所有尺寸均是毫米 [英寸]
3. 10 sprocket hole pitch cumulative tolerance $\pm 0.2\text{mm}$
4. Carrier camber is within 1mm in 100mm 装料带弧:每100mm少于1mm
5. Material: BLACK Polystyrene. 材料:黑色:聚苯乙烯
6. Packing Length Per 22' Reel: 36Meters 每22'卷筒包装长度:36米
7. Component Load Per 13' Reel: 800Pcs 每13'卷筒承载零件:800件

Packing Rules 封装规则:

1. Place a hard cardboard at the bottom of outer carton 外箱底部加纸板
2. All the labels on REEL should be face-up
Reel 标签一律朝上
3. Place 10 filled REEL into the water-proof bag
把10卷装好的产品平放防水袋
4. Place a hard cardboard on top 上加放纸板
5. Stick label on the outer carton
标签贴放箱外

By	LYH	ASE	SA
DETAIL	DRAWING RELEASE	ECN080402A	PACK QTY UPDATE
REV DATE	A 11/07/07	B 02/04/08	C 28/06/10



Tolerances (Except as noted)	Part Number:- USB2060	Date:- 11 JUL 07
Dimensions in mm	Description:- MINI USB RECEPTACLE, TYPE B, 5 PIN, SMT, HORIZONTAL	
Third Angle Projection	© THIS DRAWING IS CONFIDENTIAL AND MUST NOT BE COPIED OR DISCLOSED WITHOUT WRITTEN CONSENT	

GCT

www.globalconnectortechology.com

Scale NTS	Revision C	Material See Note	Drawn by LYH	E & OE	Sheet No. 2/2
--------------	---------------	----------------------	-----------------	--------	------------------