

PRODUCT SPECIFICATION

Part Number	USB2066	Rev	C	Date	11/06/09		
Product Description	Mini USB Receptacle, Type B, 5 Pin, SMT, Horizontal, with Post.				Page	1	
Doc Number	USB2066	Prepared	BW	Checked	PN	Approved	DR

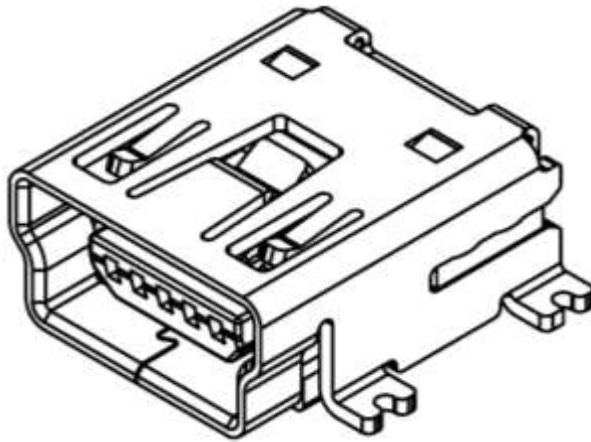

GCT

PRODUCT SPECIFICATION

Part Number	USB2066	Rev	C	Date	11/06/09		
Product Description	Mini USB Receptacle, Type B, 5 Pin, SMT, Horizontal, with Post.			Page	2		
Doc Number	USB2066	Prepared	BW	Checked	PN	Approved	DR

1.0 SCOPE.

This specification covers performance, tests and quality requirements for the Mini USB Receptacle USB 2066 (Type B, 5-Pin, SMT, Horizontal).

2.0 PRODUCT NAME AND PART NUMBER.

Mini USB Receptacle, 5 Pin, Type B: USB 2066.

3.0 PRODUCT SHAPE, DIMENSIONS AND MATERIAL.

Please refer to drawings.

4.0 RATINGS.

- 4.1 Current rating 1.0 A Max.
- 4.2 Voltage rating 30 Volts AC RMS Max.
- 4.3 Operating Temperature Range -50°C to 85°C

5.0 TEST AND MEASUREMENT CONDITIONS.

Product is designed to meet electrical, mechanical and environmental performance requirements specified in Paragraph 6.0. All tests are performed in ambient conditions unless otherwise specified.

6.0 PERFORMANCE.

Item	Test Condition	Requirement
Examination of Product	Visual, dimensional and functional inspection as per quality plan.	Product shall meet requirements of product drawing and specification.

PRODUCT SPECIFICATION

Part Number	USB2066	Rev	C	Date	11/06/09
Product Description	Mini USB Receptacle, Type B, 5 Pin, SMT, Horizontal, with Post.			Page	3
Doc Number	USB2066	Prepared	BW	Checked	PN
				Approved	DR

6.1 Electrical Performance.

Item	Test Condition	Requirement
Contact Resistance	Measure and record contact resistance of mated connector using test current of 100mA max and 20 mV open circuit voltage in accordance with EIA-364-23.	40 mΩ Initial Less than 50 mΩ at end of test
Insulation Resistance	Apply 100Volts DC between adjacent contacts of mated connectors for one minute in accordance with EIA-364-21.	Greater than 100 MΩ
Dielectric Strength	Apply 100 V AC for 1 minute between adjacent terminal ground in accordance with EIA-364-20.	No creeping discharge or flash over. Current leakage less than 0.5 mA
Capacitance	Test between adjacent circuits of unmated connectors at 1KHz in accordance with EIA-364-30.	2pF Max

6.2 Mechanical Performance.

Item	Test Condition	Requirement
Mating force	Operation Speed : 12.5mm/min. Measure the force required to mate connector. EIA-364-13	35N (3.57Kgf) Max.
Unmating Force	Operation Speed : 12.5mm/min. Measure the force required to unmate connector. EIA-364-13	Initial: 7N (0.71Kgf) Min. 1 st mating cycle Final: 3N (0.31Kgf) Min. 5001 st mating cycle
Durability	The connector should be mated and unmated for 5000 cycles at a rate of 200 cycles per hour (manual cycle) in accordance with EIA-364-09.	No evidence of physical damage. Contact Resistance ≤ 50mΩ at end of test .
Vibration	Subject mated connectors to 10-55-10 Hz traversed in 1minutes at 1.52mm amplitude, for 2 Hours each, on 3 mutually perpendicular planes. 100mA Max. Applied. EIA-364-28D	No electrical discontinuity greater than 1 μ sec. shall occur. No damage to product.

PRODUCT SPECIFICATION

Part Number	USB2066	Rev	C	Date	11/06/09
Product Description	Mini USB Receptacle, Type B, 5 Pin, SMT, Horizontal, with Post.			Page	4
Doc Number	USB2066	Prepared	BW	Checked	PN
				Approved	DR

Item	Test Condition	Requirement
Mechanical Shock	Subject mated parts to 30G half-sine shock pulses for 11 ms. Apply three shocks in each direction applied along three mutually perpendicular planes in accordance with EIA-364-27.	No electrical discontinuity greater than 1 μ sec. shall occur. No damage to product. Contact Resistance $\leq 100m\Omega$ at end of test .

6.3 Environmental Performance and Others.

Item	Test Condition	Requirement
Thermal Shock	Mate Connector and perform the following thermal cycle:- -55 \pm 3 $^{\circ}$ C to +85 \pm 2 $^{\circ}$ C. Repeat for 5 cycles in accordance with EIA-364-32, condition I.	No evidence of physical damage, discharge, flashes or corrosion in contact areas.
Humidity Test	Mate connector and expose to temperature of 40 $^{\circ}$ C and 90 to 95% RH for 96 hours in accordance with EIA-RS-364-31.	Contact Resistance less than 50m Ω at end of test.
Salt Water Spray	Subject mated connectors to 35 \pm 2 $^{\circ}$ C and 5 \pm 1% salt condition for 48hours. Test in accordance with EIA-364-26.	No evidence of physical damage, discharge, flashes or corrosion in contact areas.
Temperature Life (High)	Subject the mated connectors to temperature environment at +85 $^{\circ}$ C for 250 hours and in accordance with EIA-364-17 Test condition III, method A.	No evidence of physical damage, discharge, flashes or corrosion in contact areas.
Temperature Life (Low)	Subject product to -55 \pm 2 $^{\circ}$ C for 96 hours continuously.	No evidence of physical damage, discharge, flashes or corrosion in contact areas.
Solderability	Dip solders tails into molten solder, held at a temperature of 265 \pm 5 $^{\circ}$ C	95% of immersed area must show no voids of pin holes.
Resistance to Soldering Heat	Pre-soak condition, 85 $^{\circ}$ C, 85% RH for 168 hours. Pre Heat: 150 $^{\circ}$ C ~180 $^{\circ}$ C, 90+30sec. Heat: 230 $^{\circ}$ C Min., 30+10sec. Peak Temp.: 260 $^{\circ}$ C +0/-5, 20~40sec. Duration: 3cycles	No physical damage shall occur. (Lead-Free)

PRODUCT SPECIFICATION

Part Number	USB2066	Rev	C	Date	11/06/09		
Product Description	Mini USB Receptacle, Type B, 5 Pin, SMT, Horizontal, with Post.				Page	5	
Doc Number	USB2066	Prepared	BW	Checked	PN	Approved	DR

7.0 PRODUCT QUALIFICATION AND TEST SEQUENCE

Test Item	Test Group							
	A	B	C	D	E	F	G	H
Examination of Product	1, 4	1, 9	1, 9	1, 3	1, 5	1, 9	1, 9	1
Contact Resistance		4, 8	4, 8		2, 4	4, 8	3, 7	
Dielectric Withstanding Voltage		2, 6	2, 6			2, 6		
Insulation Resistance		3, 7	3, 7			3, 7		
Mating Force							2, 6	
Unmating Force							4, 8	
Durability							5	
Capacitance								2
Vibration	2							
Physical Shock	3							
Thermal Shock			5					
Solderability				2				
Temperature Life		5						
Humidity Test						5		

PRODUCT SPECIFICATION

Part Number	USB2066	Rev	C	Date	11/06/09		
Product Description	Mini USB Receptacle, Type B, 5 Pin, SMT, Horizontal, with Post.			Page	6		
Doc Number	USB2066	Prepared	BW	Checked	PN	Approved	DR

Revision details :-

Revision	Information	Page	Release Date
A	Specification Released	-	11/06/2009
B	Operating Temperature: Was 0°C to +50°C Now -20°C to 60°C	2	18/10/2010
	Mating and unmating force replaces contact force	3	
	Vibration test conditions updated	3	
	Mechanical shock test conditions updated	4	
	Humidity Test, test conditions updated	4	
	Temperature Life - split into High and Low	4	
	Solderability temperature updated	4	
	Resistance to Soldering Heat added	4	
	Product Qualification and Test Sequence updated	5	
C	Operating Temperature: Was -20°C to +60°C Now -50°C to +85°C	2	07/12/2011

Contact details

Asia Pacific

Global Connector Technology HK Limited
Unit 1204, 12/F, Fortress Tower,
250 King's Road
North Point,
Hong Kong, PRC.

Tel: +852 2578 9030
Fax: +852 2578 9000
Email: sales@gct-apac.com

Americas

Global Connector Technology, Inc.
3 Industrial Park Road,
Medway, MA 02053
USA

Tel: +1 508-570-2438
E-mail: sales@gct-americas.com

Europe

Global Connector Technology Europe Limited
7 Sutherland Court
Brownfields
Welwyn Garden City, Hertfordshire
AL7 1BJ
United Kingdom.

Tel: +44 (0)1707 321122
Fax: +44 (0)1707 321121
E-mail: sales@gct-europe.com

Global Connector Technology Limited makes no representation that the use of its products in the circuits described herein, or the use of other technical information contained herein, will not infringe upon existing or future patent rights. The descriptions contained herein do not imply the granting of licenses to make, use, or sell equipment constructed in accordance therewith. Specifications are subject to change without notice. Errors and Omissions Excepted.

GCT

www.globalconnectortechnology.com