

PRODUCT SPECIFICATION

Part Number	USB3050	Rev	A	Date	11/06/09		
Product Description	Micro USB Receptacle ,Type B, 5 Pin, SMT, Horizontal				Page	1	
Doc Number	USB3050	Prepared	BW	Checked	PN	Approved	DR

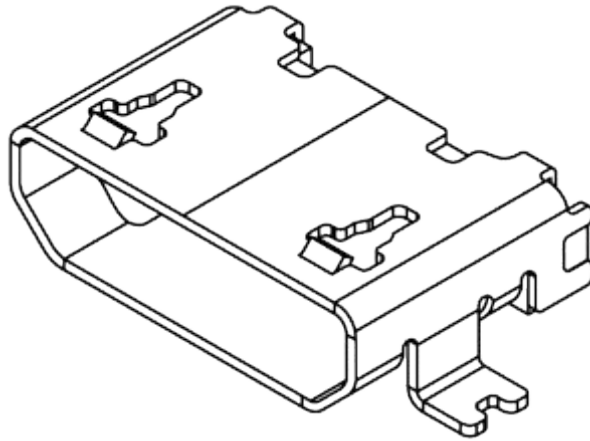

GCT

PRODUCT SPECIFICATION

Part Number	USB3050	Rev	A	Date	11/06/09		
Product Description	Micro USB Receptacle ,Type B, 5 Pin, SMT, Horizontal				Page	2	
Doc Number	USB3050	Prepared	BW	Checked	PN	Approved	DR

1.0 SCOPE.

This specification covers performance, tests and quality requirements for the Micro USB Receptacle USB3050 (Type B, 5-Pin, SMT, Horizontal).

2.0 PRODUCT NAME AND PART NUMBER.

Micro USB Receptacle, 5 Pin, Type B: USB 3050.

3.0 PRODUCT SHAPE, DIMENSIONS AND MATERIAL.

Please refer to drawings.

4.0 RATINGS.

- 4.1 Current rating 1.0 A Max (Signal Contacts) 1.8A Max (Power contacts).
- 4.2 Voltage rating 100 Volts AC (RMS) max.
- 4.3 Operating Temperature Range TBD
- 4.4 Storage Temperature -25 to +85°C

5.0 TEST AND MEASUREMENT CONDITIONS.

Product is designed to meet electrical, mechanical and environmental performance requirements specified in Paragraph 6.0. All tests are performed in ambient conditions unless otherwise specified.

6.0 PERFORMANCE.

Item	Test Condition	Requirement
Examination of Product	Visual, dimensional and functional inspection as per quality plan.	Product shall meet requirements of product drawing and specification.

PRODUCT SPECIFICATION

Part Number	USB3050	Rev	A	Date	11/06/09		
Product Description	Micro USB Receptacle ,Type B, 5 Pin, SMT, Horizontal				Page	3	
Doc Number	USB3050	Prepared	BW	Checked	PN	Approved	DR

6.1 Electrical Performance.

Item	Test Condition	Requirement
Contact Resistance	Measure and record contact resistance of mated connector using test current of 100mA max and 20 mV open circuit voltage in accordance with EIA-364-23.	Less than 30 mΩ before test Less than 40 mΩ at end of test
Insulation Resistance	Apply 500Volts DC between adjacent contacts of mated connectors for one minute in accordance with EIA-364-21.	Greater than 100 MΩ
Dielectric Strength	Mate connectors and apply 500 V AC for 1 minute between adjacent terminal ground in accordance with EIA-364-20.	No creeping discharge or flash over. Current Leakage 0.5 mA max.
Capacitance	Test between adjacent circuits of unmated connectors at 1Khz in accordance with EIA-364-30.	2pF Max unmated per contact

6.2 Mechanical Performance.

Item	Test Condition	Requirement
Contact force	Apply axial pull out force on the connector assembled in the housing at a speed: 25 ± 3 mm/minute. In accordance with EIA364-29.	100g/pin Min
Durability	The connector should be mated and unmated for 10000 cycles at a rate of 12.5 mm/min in accordance with EIA-364-09.	No evidence of physical damage. Contact Resistance ≤ 50mΩ at end of test .
Vibration	Subject mated parts to a frequency span of 10 to 55Hz with amplitude of 1.5 mm for 2hrs in each of 3 mutually perpendicular planes in accordance with EIA-364-28.	No electrical discontinuity greater than 1 μ sec. shall occur. No damage to product.
Mechanical Shock	Subject mated parts to an acceleration of 294 m/s ² with half-sine shock pulses for 11 ms. Apply three shocks in each direction applied along three mutually perpendicular planes in accordance with EIA-364-27B.	No electrical discontinuity greater than 1 μ sec. shall occur. No damage to product. Contact Resistance ≤ 100mΩ at end of test .

PRODUCT SPECIFICATION

Part Number	USB3050	Rev	A	Date	11/06/09		
Product Description	Micro USB Receptacle ,Type B, 5 Pin, SMT, Horizontal				Page	4	
Doc Number	USB3050	Prepared	BW	Checked	PN	Approved	DR

6.3 Environmental Performance and Others.

Item	Test Condition	Requirement
Thermal Shock	Mate Connector and perform the following thermal cycle :- -55+/-3°C (30 min) to +85+/-2°C (30 min). Repeat for 5 cycles in accordance with EIA-364-32C	No evidence of physical damage, discharge, flashes or corrosion in contact areas. Contact Resistance Less than 50mΩ at end of test. Insulation Resistance greater than 100MΩ at end of test. Dielectric Strength Current leakage less than 0.5 mA
Humidity Test	Mate connector and expose to temperature of 40°C and 90 to 98% RH for 96 hrs in accordance with EIA-364-31.	
Salt Water Spray	Subject mated connectors to 35±2°C and 5±1% salt condition for 48hours. Test in accordance with EIA-364-26.	
Temperature Life	Subject mated connectors to 85 ± 2°C for 250 hours continuously in accordance with EIA-364-17.	
Temperature Rise	Apply test current to the circuit, and measure the temperature rising by probing on soldered areas of contacts and after the temperature becomes stabilized deduct ambient temperature from the measured value.	30°C maximum under load
Solderability	Dip solders tails into molten solder, held at a temperature of 235 ± 3°C, for 3 cycles in accordance with EIA-364-52.	95% of immersed area must show no voids of pin holes.
Resistance to Reflow Soldering Heat.	Mount connector, place in reflow oven and expose to the temperature profile shown in fig 1.0.	No evidence of physical damage or abnormalities adversely affecting performance.

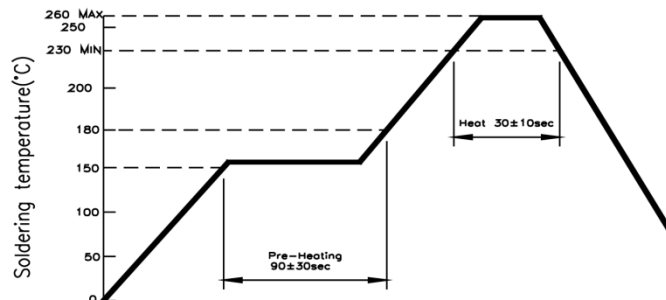

Fig.1. Recommended Reflow Temp. Profile

PRODUCT SPECIFICATION

Part Number	USB3050	Rev	A	Date	11/06/09		
Product Description	Micro USB Receptacle ,Type B, 5 Pin, SMT, Horizontal				Page	5	
Doc Number	USB3050	Prepared	BW	Checked	PN	Approved	DR

7.0 PRODUCT QUALIFICATION AND TEST SEQUENCE

Test Item	Group							
	A	B	C	D	E	F	G	H
Examination of	1,5	1,5	1,5	1,8	1,7	1,6	1,4	1,3
Contact Resistance	2,4	2,4	2,4	2,6	2,6	2,5		
Insulation Resistance				3,5				
Dielectric Withstanding Voltage				7				
Mechanical shock						4		
Contact force							3	
Durability					4			
Vibration						3		
Humidity				4				
Salt Water Spray		3						
Temperature Life			3					
Thermal Shock	3							
Solderability								2
Resistance to Reflow Soldering Heat.							2	
Sample QTY.	5	5	5	5	5	5	5	5

Notes:

Numbers indicate sequence in which tests are performed.

Precondition samples with 10 cycle's durability.

SAMPLE SELECTION

Samples shall be prepared in accordance with applicable manufactures' instructions and shall be randomly selected from current production. Test groups A,B,C,D, etc, shall consist of a minimum of five connectors. A minimum of 30 contacts shall be selected and identified.

Unless otherwise specified, these contacts shall be used for all measurements.

Contact details

Asia Pacific

Global Connector Technology HK Limited
Unit 1204, 12/F, Fortress Tower,
250 King's Road
North Point,
Hong Kong, PRC.

Tel: +852 2578 9030
Fax: +852 2578 9000
Email: sales@gct-apac.com

Americas

Global Connector Technology, Inc.
3 Industrial Park Road,
Medway, MA 02053
USA

Tel: +1 508-570-2438
E-mail: sales@gct-americas.com

Europe

Global Connector Technology Europe Limited
7 Sutherland Court
Brownfields
Welwyn Garden City, Hertfordshire
AL7 1BJ
United Kingdom.

Tel: +44 (0)1707 321122
Fax: +44 (0)1707 321121
E-mail: sales@gct-europe.com

Global Connector Technology Limited makes no representation that the use of its products in the circuits described herein, or the use of other technical information contained herein, will not infringe upon existing or future patent rights. The descriptions contained herein do not imply the granting of licenses to make, use, or sell equipment constructed in accordance therewith. Specifications are subject to change without notice. Errors and Omissions Excepted.

GCT

www.globalconnectortechnology.com