

PRODUCT SPECIFICATION

Part Number	USB3065	Rev	B	Date	18/04/11		
Product Description	Micro USB Receptacle, Type B, 5 Pin, SMT, Horizontal, Bottom Mount, Optional Plastic Locating Peg			Page	1		
Doc Number	USB3065	Prepared	CM	Checked	DR	Approved	LH

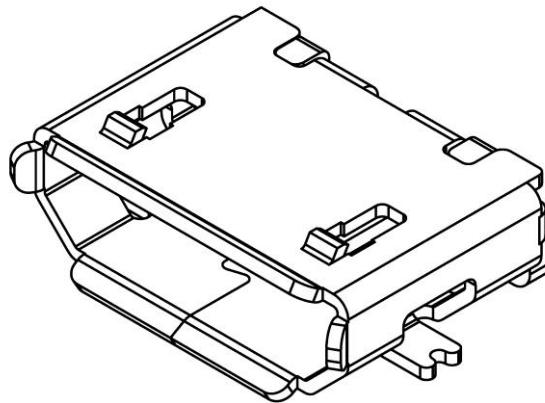

GCT

PRODUCT SPECIFICATION

Part Number	USB3065	Rev	B	Date	18/04/11		
Product Description	Micro USB Receptacle, Type B, 5 Pin, SMT, Horizontal, Bottom Mount, Optional Plastic Locating Peg			Page	2		
Doc Number	USB3065	Prepared	CM	Checked	DR	Approved	LH

1.0 SCOPE.

This specification covers performance, tests and quality requirements for the Micro USB Receptacle USB3065 (Type B, 5-Pin, SMT, Horizontal).

2.0 PRODUCT NAME AND PART NUMBER.

Micro USB Receptacle, 5 Pin, Type B: USB3065.

3.0 PRODUCT SHAPE, DIMENSIONS AND MATERIAL.

Please refer to drawings.

4.0 RATINGS.

- 4.1 Current rating: Signal (Pins 2, 3, 4) 1.0A
- Power (Pins1, 5)..... 1.8A
- 4.2 Voltage rating 100V AC
- 4.3 Operating Temperature Range -20°C to +85°C

5.0 TEST AND MEASUREMENT CONDITIONS.

Product is designed to meet electrical, mechanical and environmental performance requirements specified in Paragraph 6.0. All tests are performed in ambient conditions unless otherwise specified.

6.0 PERFORMANCE.

Item	Test Condition	Requirement
Examination of Product	Visual, dimensional and functional inspection as per quality plan.	Product shall meet requirements of product drawing and specification.

PRODUCT SPECIFICATION

Part Number	USB3065	Rev	B	Date	18/04/11		
Product Description	Micro USB Receptacle, Type B, 5 Pin, SMT, Horizontal, Bottom Mount, Optional Plastic Locating Peg			Page	3		
Doc Number	USB3065	Prepared	CM	Checked	DR	Approved	LH

6.1 Electrical Performance.

Item	Test Condition	Requirement
Low-signal Level Contact Resistance	Mate connectors, measure by dry circuit, 20 mV Max. In accordance with EIA-364-23.	30 mΩ Max.
Insulation Resistance	Mate/Un-mate connectors, apply 100V DC for 1 minute between adjacent terminal or ground. In accordance with EIA-364-21.	1000 MΩ Min.
Dielectric Strength	Mate/Un-mate connectors, apply 250V AC (rms) for 1 minute between adjacent terminal or ground. In accordance with EIA-364-20.	No Breakdown. Current Leakage: <0.5 mA.

6.2 Mechanical Performance.

Item	Test Condition	Requirement
Mating/Un-mating Force (initial)	Mate/Un-mated at a rate of 12.5mm/min. In accordance with EIA-364-13.	Mating force: 35N Max. Un-Mating force: 8N Min.
Durability	Cycle rate, 500 cycles per hour if done automatically and 200 if manual cycles. In accordance with EIA-364-09.	10,000 cycles.
Vibration	Test condition V test letter A, mate connectors and subject to 5.35 Gs RMS. For a period of 15 minutes in each of the 3 mutually perpendicular axes. In accordance with EIA-364-09.	Appearance: No Damage. Contact Resistance: 30 mΩ Max. Discontinuity: 1.0 μ second Max.
Mechanical Shock	Mate connectors and subject to the following shock conditions, 3 shocks shall be applied along 3 mutually perpendicular axes, passing 100 mA current during the test. (Total of 18 shocks) Test Pulse: Half Sine Peak Value: 294 m/s ² (30G) Duration: 11ms. In accordance with EIA-364-27.	Appearance: No Damage. Contact Resistance: 30 mΩ Max. Discontinuity: 1.0 μ second Max.

PRODUCT SPECIFICATION

Part Number	USB3065	Rev	B	Date	18/04/11		
Product Description	Micro USB Receptacle, Type B, 5 Pin, SMT, Horizontal, Bottom Mount, Optional Plastic Locating Peg			Page	4		
Doc Number	USB3065	Prepared	CM	Checked	DR	Approved	LH

6.3 Environmental Performance and Others.

Item	Test Condition	Requirement
Humidity Test	Test condition A method III subject mated connectors to Duration: 168 hours temperature between -25°C to +65°C with 90 to 95% RH. In accordance with EIA-364-31.	Appearance: No Damage. Contact Resistance: 30 mΩ Max. Insulation Resistance: 100 MΩ Min. Dielectric Strength: No Breakdown.
Salt Spray	Subject mated/unmated connectors to 5% salt-solution concentration, 35°C for 48 hours. In accordance with EIA-364-26, Test Condition B.	100 mΩ Max.
Temperature Life	Subject mated connectors to temperature life at 85 for 500hours. In accordance with EIA-364-17, test condition 2 Method A.	30 mΩ Max. Shall meet visual requirement and show no physical damage.
Temperature Rise	Mate connector and measure the temperature rise of contact when the maximum AC rated current is passed and in accordance with EIA-364-70.	+30°C Max.
Solderability	Dip solder-tails in flux then immerse in solder bath at 245 ±5°C up to 0.5mm from the bottom of the housing for 4~5 seconds. In accordance with EIA-364-52, category 2.	95% of immersed area must show no voids, pin holes.
Resistance to Soldering Heat (Reflow Soldering)	Sample mounted on PCB and subject to wave soldering, Temperature: 260±5°C for 10+2/-0 sec (High Temp. Thermoplastic).	No Damage.
Mixed Flowing Gas	C12; 10±3 NO ₂ ; 200±50 H ₂ S; 10±5 (ppb), SO ₂ ; 100±20. 1. Mating Conditions: 5 days. 2. Unmated: 5 days mated. Temperature: 30 ±1°C. Humidity: 70 ±2% R.H. In accordance with EIA-364-65, Class IIA Exposures.	1. Shall meet visual requirement and show no physical damage. 2. Shall meet requirements of additional tests. 3. 30 mΩ Max.

PRODUCT SPECIFICATION

Part Number	USB3065	Rev	B	Date	18/04/11		
Product Description	Micro USB Receptacle, Type B, 5 Pin, SMT, Horizontal, Bottom Mount, Optional Plastic Locating Peg			Page	5		
Doc Number	USB3065	Prepared	CM	Checked	DR	Approved	LH

7.0 PRODUCT QUALIFICATION AND TEST SEQUENCE

Test Item	Test Group										
	A	B	C	D	E	F	G	H	I	J	K
Examination of Product	15	14	15	14	14	16	14	14	13	13	13
Low-signal Level Contact Resistance	2	25	26	25	25	27	25	25			
Insulation Resistance	3					38					
Dielectric Withstanding Voltage	4					49					
Temperature Rise		3									
Mating / Unmating Forces			3								
Durability			4								
Vibration				3							
Mechanical Shock					3						
Humidity						5					
Temperature Life							3				
Mixed Flowing Gas								3			
Solderability									2		
Resistance to Reflow Soldering Heat										2	
Salt Spray											2

PRODUCT SPECIFICATION

Part Number	USB3065	Rev	B	Date	18/04/11		
Product Description	Micro USB Receptacle, Type B, 5 Pin, SMT, Horizontal, Bottom Mount, Optional Plastic Locating Peg			Page	6		
Doc Number	USB3065	Prepared	CM	Checked	DR	Approved	LH

Revision details :-

Revision	Information	Page	Release Date
A	Specification released.	-	18/04/11
B	New current rating.	2	31/10/11

GCT

Contact details

Asia Pacific

Global Connector Technology HK Limited
Unit 1204, 12/F, Fortress Tower
250 King's Road
North Point
Hong Kong, PRC

Tel: +852 2578 9030
Fax: +852 2578 9000
Email: sales@gct-apac.com

Americas

Global Connector Technology, Inc.
686 South Street, Unit 7
Wrentham, MA 02093
USA

Tel: +1 508-384-5025
Fax: +1 508 796 6162
E-mail: sales@gct-americas.com

Europe

Global Connector Technology Europe Limited
7 Sutherland Court
Brownfields
Welwyn Garden City, Hertfordshire
AL7 1BJ
United Kingdom

Tel: +44 (0)1707 321122
Fax: +44 (0)1707 321121
E-mail: sales@gct-europe.com

Global Connector Technology Limited makes no representation that the use of its products in the circuits described herein, or the use of other technical information contained herein, will not infringe upon existing or future patent rights. The descriptions contained herein do not imply the granting of licenses to make, use, or sell equipment constructed in accordance therewith. Specifications are subject to change without notice (errors and omissions excepted).

GCT

www.globalconnectortechnology.com