

PRODUCT SPECIFICATION

Part Number	USB3125	Rev	B	Date	15/06/11		
Product Description	USB3.0 Micro Receptacle, Type AB, SMT, Horizontal, 10 Pin, Bottom mount, with SMT Holddown Pads			Page	1		
Doc Number	USB3125	Prepared	CM	Checked	DR	Approved	LH

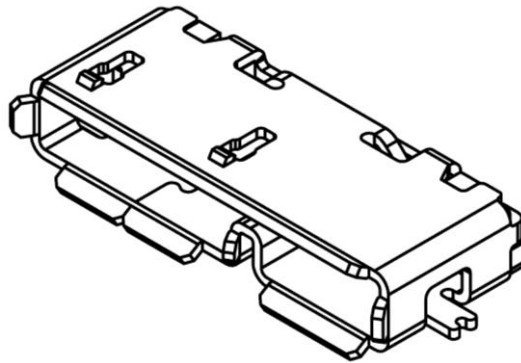

GCT

PRODUCT SPECIFICATION

Part Number	USB3125	Rev	B	Date	15/06/11		
Product Description	USB3.0 Micro Receptacle, Type AB, SMT, Horizontal, 10 Pin, Bottom mount, with SMT Holdown Pads			Page	2		
Doc Number	USB3125	Prepared	CM	Checked	DR	Approved	LH

1.0 SCOPE.

This specification covers performance, tests and quality requirements for the USB3.0 Receptacle USB3125 (Type AB, 10-Pin, SMT, Horizontal).

2.0 PRODUCT NAME AND PART NUMBER.

USB3.0 Receptacle, 10-Pin, Type AB: USB3125.

3.0 PRODUCT SHAPE, DIMENSIONS AND MATERIAL.

Please refer to drawings.

4.0 RATINGS.

- 4.1 Current rating 1.5 A
- 4.2 Voltage rating 30 VAC
- 4.3 Operating Temperature Range -20°C to +60°C

5.0 TEST AND MEASUREMENT CONDITIONS.

Product is designed to meet electrical, mechanical and environmental performance requirements specified in Paragraph 6.0. All tests are performed in ambient conditions unless otherwise specified.

6.0 PERFORMANCE.

Item	Test Condition	Requirement
Examination of Product	Visual, dimensional and functional inspection as per quality plan.	Product shall meet requirements of product drawing and specification.

PRODUCT SPECIFICATION

Part Number	USB3125	Rev	B	Date	15/06/11		
Product Description	USB3.0 Micro Receptacle, Type AB, SMT, Horizontal, 10 Pin, Bottom mount, with SMT Holdown Pads			Page	3		
Doc Number	USB3125	Prepared	CM	Checked	DR	Approved	LH

6.1 Electrical Performance.

Item	Test Condition	Requirement
Low-signal Level Contact Resistance	Mate connectors, measure by dry circuit, 20mV Max., 100mA Max. In accordance with EIA-364-23.	Initial: Contact $\leq 30\text{m}\Omega$ Shell $\leq 50\text{m}\Omega$ After Test: Contact $\Delta 20\text{m}\Omega$ Max. Shell $\Delta 20\text{m}\Omega$ Max.
Insulation Resistance	Unmated connector, mounted to a PCB: apply a voltage of 500 VDC between adjacent terminals and between terminals to ground.	1000M Ω Min.
Dielectric Withstanding Voltage	750 VAC rms (1mA cut off current) for 60seconds duration between adjacent terminals and terminals.	No breakdown.
Capacitance	Measured between adjacent circuits of un-mated connectors at 1kHz. In accordance with EIA-364-30.	2 pF Max.
Temperature Rise	Mate connector and measure the temperature rise of contact when the maximum AC rated current is passed. In accordance with EIA-364-70.	1.5A at 250 VAC Min. & Temperature rise: +30°C Max.

6.2 Mechanical Performance.

Item	Test Condition	Requirement
Mating / Unmating Force	Mated and unmated at rate of 200 \pm 50 cycles per hour. In accordance with EIA-364-13.	Initial: Mating force: 35N Max. Un-mating force: 10N Min. Final (after 10k cycles): Mating force: 35N Max. Un-mating force: 8N Min.
Durability	Insertion and withdrawal are repeated with card at the frequency of 550 cycles / hour max. In accordance with EIA-364-09.	10,000 cycles
Vibration	Mated connector and subject to the following vibration condition, for a period of 15 minutes in each 3 mutually perpendicular axes. In accordance with EIA-364-28, Test condition V, Test letter A.	Appearance: No Damage Contact Resistance: 30m Ω Max. Discontinuity: 1.0 μ second Max.

PRODUCT SPECIFICATION

Part Number	USB3125	Rev	B	Date	15/06/11		
Product Description	USB3.0 Micro Receptacle, Type AB, SMT, Horizontal, 10 Pin, Bottom mount, with SMT Holddown Pads			Page	4		
Doc Number	USB3125	Prepared	CM	Checked	DR	Approved	LH

Item	Test Condition	Requirement
Terminal Retention	Apply a pull out force in the axial direction of the contact per Mil-STD-1344A method 2007.1.	0.8 Kgf Min.
Mechanical Shock	Mate connectors and subject to the following shock conditions, 3 shocks shall be applied along 3 mutually perpendicular axes, passing 100 mA current during the test. (Total of 18 shocks) Test Pulse: Half Sine Peak Value: 294 m/s ² (30G) Duration: 11ms. In accordance with EIA-364-27.	Appearance: No Damage. Contact Resistance: 30mΩ Max. Discontinuity: 1.0μ second Max.

6.3 Environmental Performance and Others.

Item	Test Condition	Requirement
Thermal Shock	Subject mated connector to 10 cycles of exposure at -55°C and 85°C. In accordance with EIA-364-32.	Contact Resistance: 30 mΩ Max.
Humidity Test	Mate connectors; Temperature: 40+/-2°C. Relative humidity: 90-95%. Duration time: 168 hours.	Contact Resistance: 30 mΩ Max.
Temperature Life	Subject mated connector to ambient temperature 125°C for 250 hours. In accordance with Mil-STD-1344A, method 1005.1 condition B.	30 mΩ Max. Shall meet visual requirement and show no physical damage.
Solderability	Dip solder-tails in flux then immerse in solder bath at 245+/- 5 °C up to 0.5mm from the bottom of the housing for 4 ~ 5 seconds. In accordance with EIA-364-52 Category 2.	95% of immersed area must show no voids, pin holes.
Solder Resistance	Dip connector terminal tails in solder: Solder Duration: 5±0.5 seconds Solder Temperature: 260±5°C Solder Iron Duration: 4-5 seconds Solder Iron Temperature: 350±10°C In accordance with MIL-STD-202F.	No Damage.
Resistance to Reflow Soldering Heat	Place connector in IR reflow, peak temperature: 260 ± 5°C for 5±1 seconds.	No Damage.

PRODUCT SPECIFICATION

Part Number	USB3125	Rev	B	Date	15/06/11
Product Description	USB3.0 Micro Receptacle, Type AB, SMT, Horizontal, 10 Pin, Bottom mount, with SMT Holdown Pads			Page	5
Doc Number	USB3125	Prepared	CM	Checked	DR
				Approved	LH

6.4 Infrared Reflow Condition

Fig. 1. Lead-free Process: Duration = 2 Times

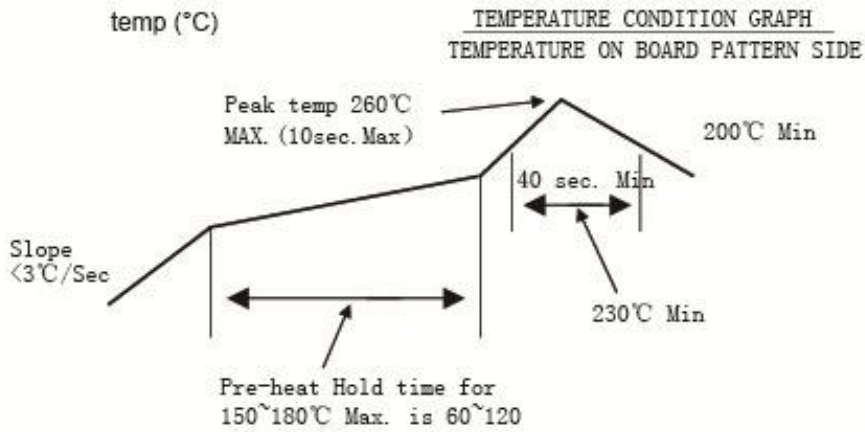

PRODUCT SPECIFICATION

Part Number	USB3125	Rev	B	Date	15/06/11		
Product Description	USB3.0 Micro Receptacle, Type AB, SMT, Horizontal, 10 Pin, Bottom mount, with SMT Holdown Pads			Page	6		
Doc Number	USB3125	Prepared	CM	Checked	DR	Approved	LH

7.0 PRODUCT QUALIFICATION AND TEST SEQUENCE

Test Item	Test Group						
	A	B	C	D	E	F	G
Examination of Product	1, 10	1, 5	1, 7	1, 9	1, 3	1, 3	1, 3
Low-signal Contact Resistance	3, 7	2, 4	2, 4, 6				
Insulation Resistance				3, 7			
Dielectric Withstanding Voltage				4, 8			
Contact Capacitance				2			
Temperature Rise						2	
Mating / Unmating Force	2, 8						
Durability	4						
Vibration	6						
Shock (Mechanical)	5						
Cable Pull-out Force	9						
Humidity				5			
Thermal Shock				6			
Temperature life		3					
Mixed Flowing Gas			3, 5				
Solderability					2		
Resistance to hand soldering heat							2

Sample Size	8	8	8	8	8	8	8
-------------	---	---	---	---	---	---	---

PRODUCT SPECIFICATION

Part Number	USB3125	Rev	B	Date	15/06/11		
Product Description	USB3.0 Micro Receptacle, Type AB, SMT, Horizontal, 10 Pin, Bottom mount, with SMT Holdown Pads			Page	7		
Doc Number	USB3125	Prepared	CM	Checked	DR	Approved	LH

Revision details :-

Revision	Information	Page	Release Date
A	Specification released.	-	15/06/11
B	General process removed.	5	05/01/12

GCT

Contact details

Asia Pacific

Global Connector Technology HK Limited
Unit 1204, 12/F, Fortress Tower
250 King's Road
North Point
Hong Kong, PRC

Tel: +852 2578 9030
Fax: +852 2578 9000
Email: sales@gct-apac.com

Americas

Global Connector Technology, Inc.
686 South Street, Unit 7
Wrentham, MA 02093
USA

Tel: +1 508-384-5025
Fax: +1 508 796 6162
E-mail: sales@gct-americas.com

Europe

Global Connector Technology Europe Limited
7 Sutherland Court
Brownfields
Welwyn Garden City, Hertfordshire
AL7 1BJ
United Kingdom

Tel: +44 (0)1707 321122
Fax: +44 (0)1707 321121
E-mail: sales@gct-europe.com

Global Connector Technology Limited makes no representation that the use of its products in the circuits described herein, or the use of other technical information contained herein, will not infringe upon existing or future patent rights. The descriptions contained herein do not imply the granting of licenses to make, use, or sell equipment constructed in accordance therewith. Specifications are subject to change without notice (errors and omissions excepted).

GCT

www.globalconnectortechnology.com